

## Typical Connections:

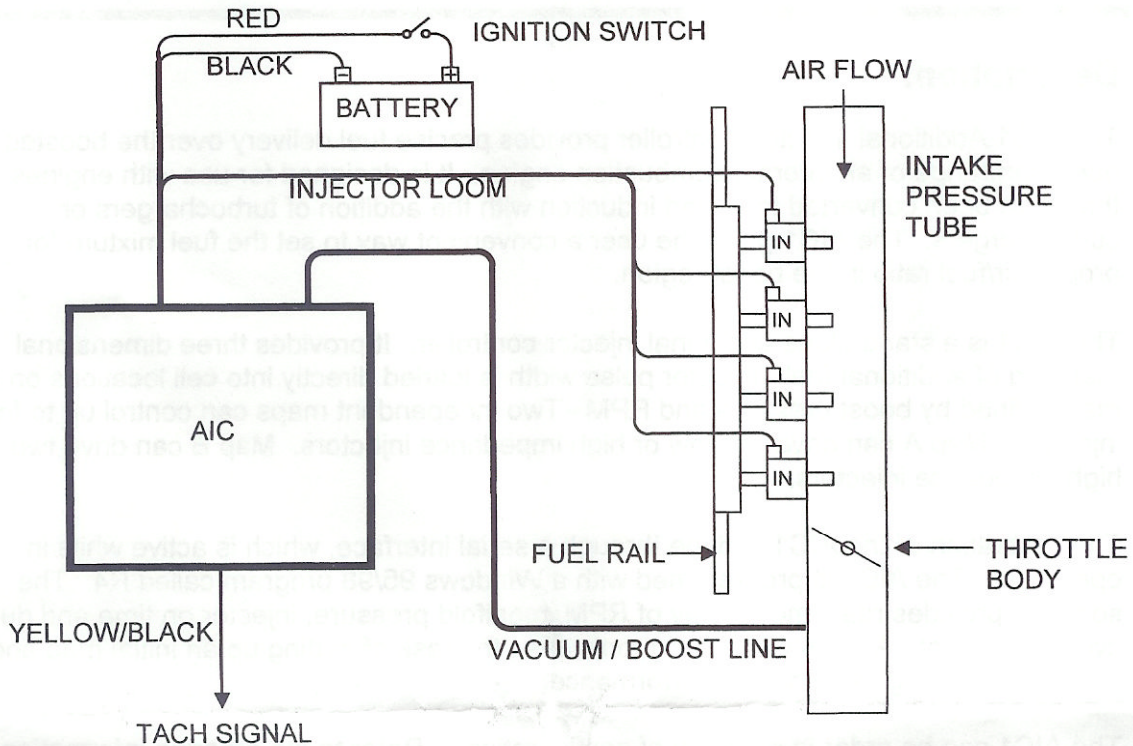

## Typical Wire Assignments:

LABEL	CONNECT TO	Map Table	WIRE COLOR
BATT+	Battery positive (+12V)		Red
BATT-	Battery negative (chassis ground)		Black
INJA+	Injector plug positive (+12V)		Red (2)
INJA-	Injector plug negative (injector driver)	A	Tan (2)
INJB+	Injector plug positive (+12V)		Red (2)
INJB-	Injector plug negative (injector driver)	B	Tan/Black (2)
TACH	Tach signal (pulses per rev = #cyl/2)		Yellow/Black
F-DB9	Serial connector on computer		-